



Fire Fighting Boat



OUR PRODUCTS MARINE USE



Car Ferry

Pleasure Boat



Tug Boat



Fishing Boat

by permission of
Sunseeker
International Ltd /
90 Yacht



Fishery Research Boat

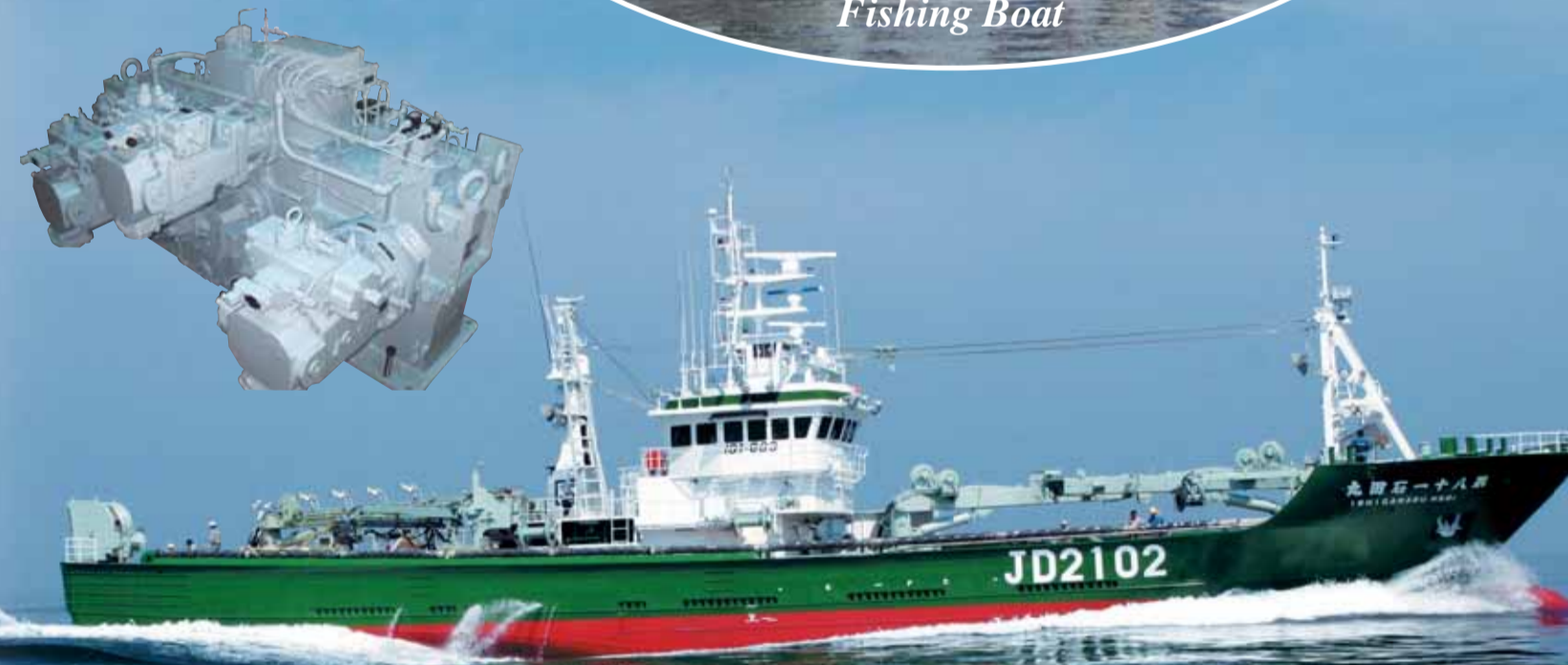

Purse Seiner



Cement Carrier



Supply Boat



Oil Tanker

by permission of MAEHATA shipbuilding Co., Ltd.

Hitachi Nico Transmission Co., Ltd.



OUR PRODUCTS for MARINE USE

CA: Max. Capacity (kW)
GR: Max. Gear Ratio
MS: Mass (kg)

MARINE GEAR for HIGH SPEED ENGINE

CAST IRON CASING

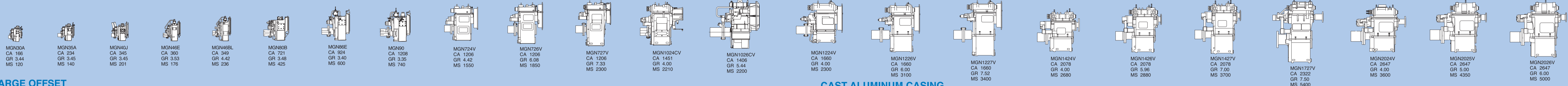

LARGE OFFSET

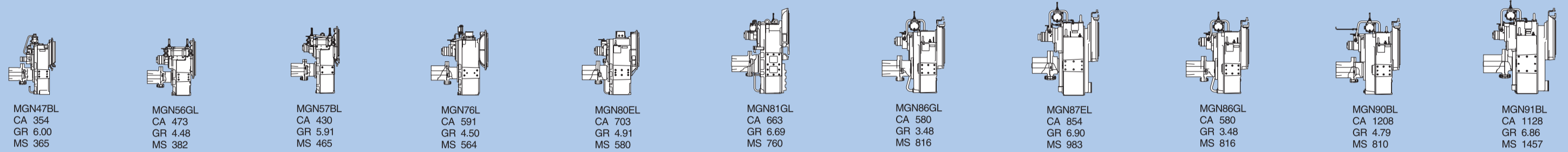

CAST ALUMINUM CASING

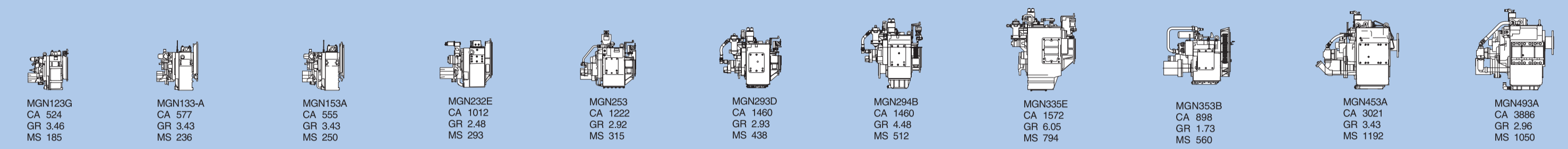

CONICAL MARINE GEAR

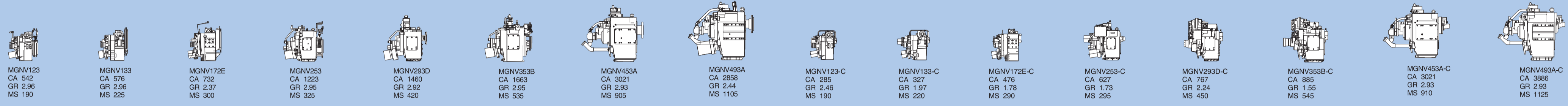

with OMEGA-CLUTCH

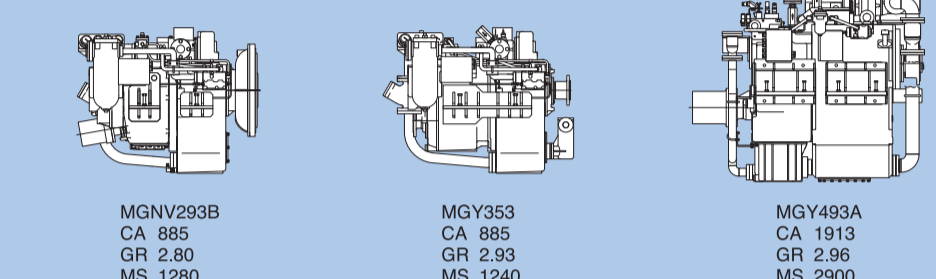

Two SPEED MARINE GEAR

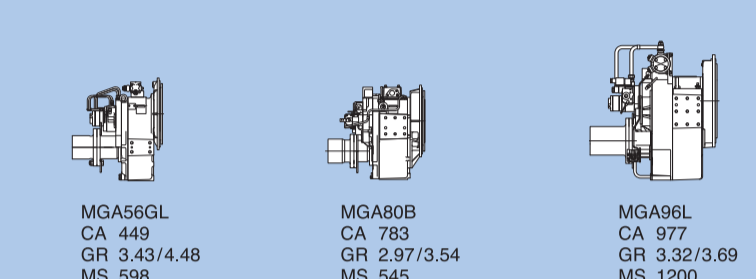

MARINE GEAR for MEDIUM SPEED ENGINE

VERTICAL OFF-SET TYPE

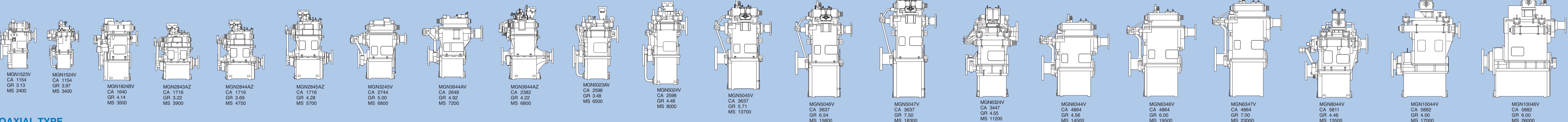

COAXIAL TYPE

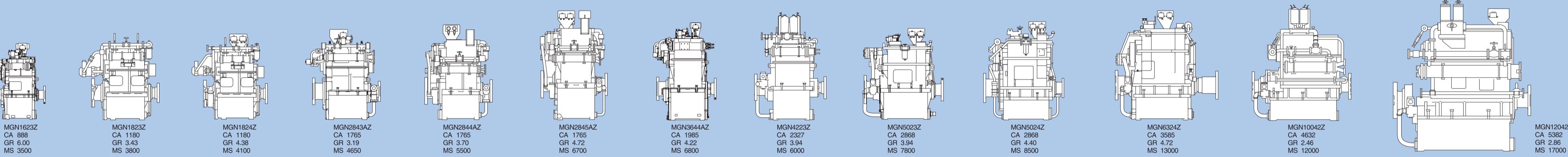

EPOCYCLIC GEAR

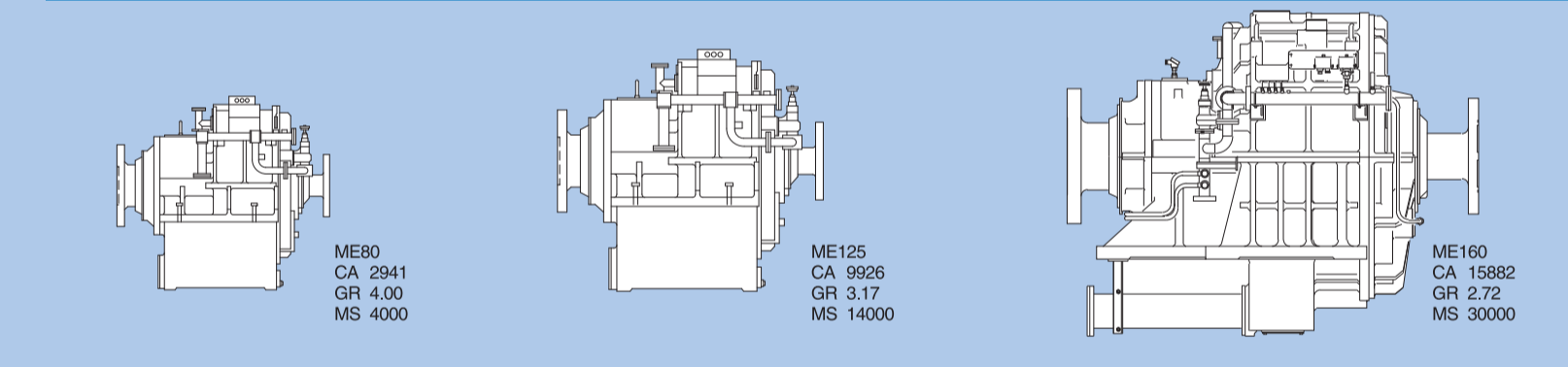

MARINE GEAR for LOW SPEED ENGINE

VERTICAL OFF-SET TYPE

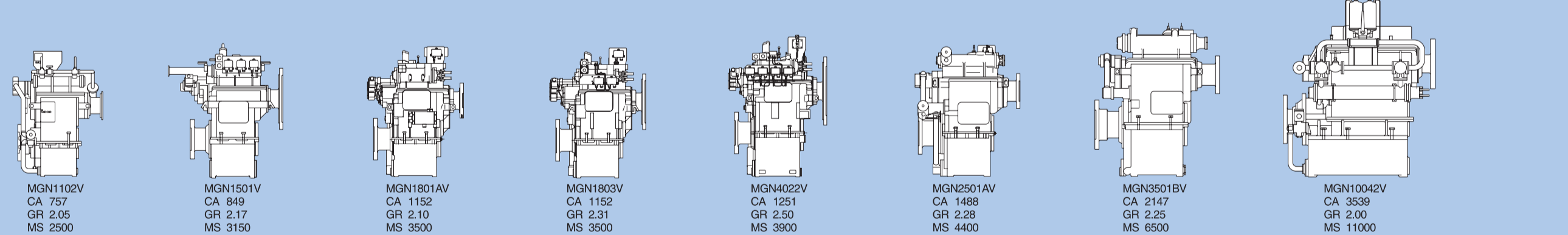

COAXIAL TYPE

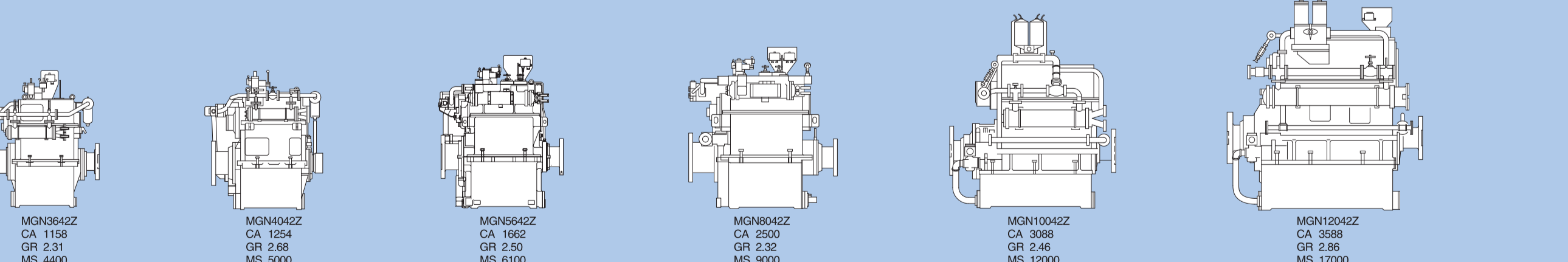

REVERSE GEAR

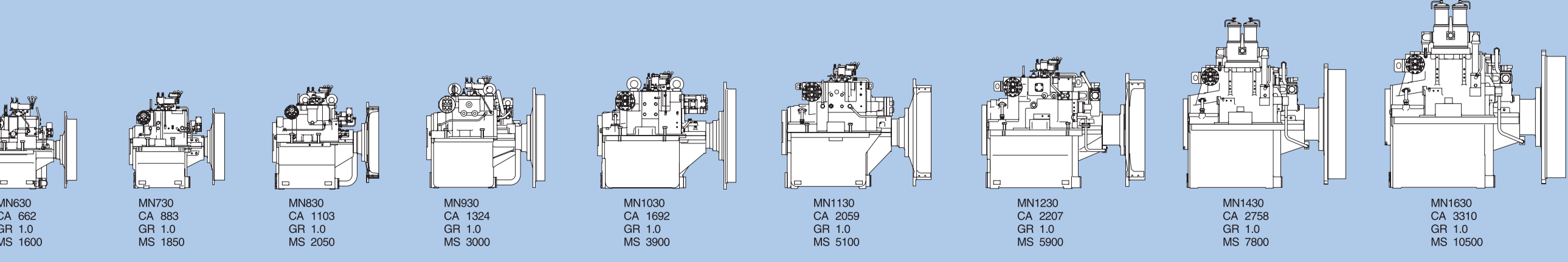

HYDRAULIC CLUTCH with MAIN THRUST BEARING

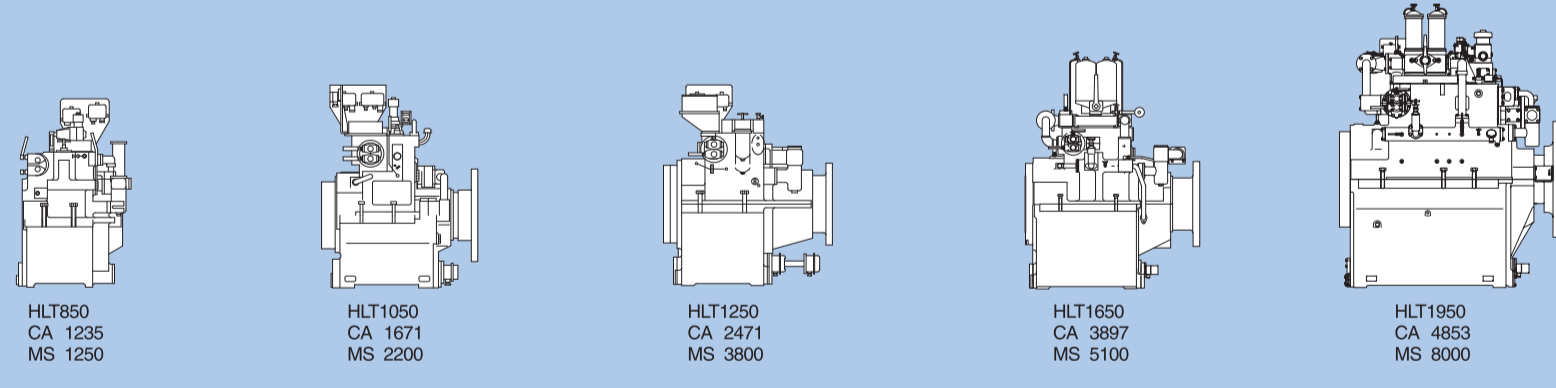

CONTRA-ROTATING MARINE GEAR

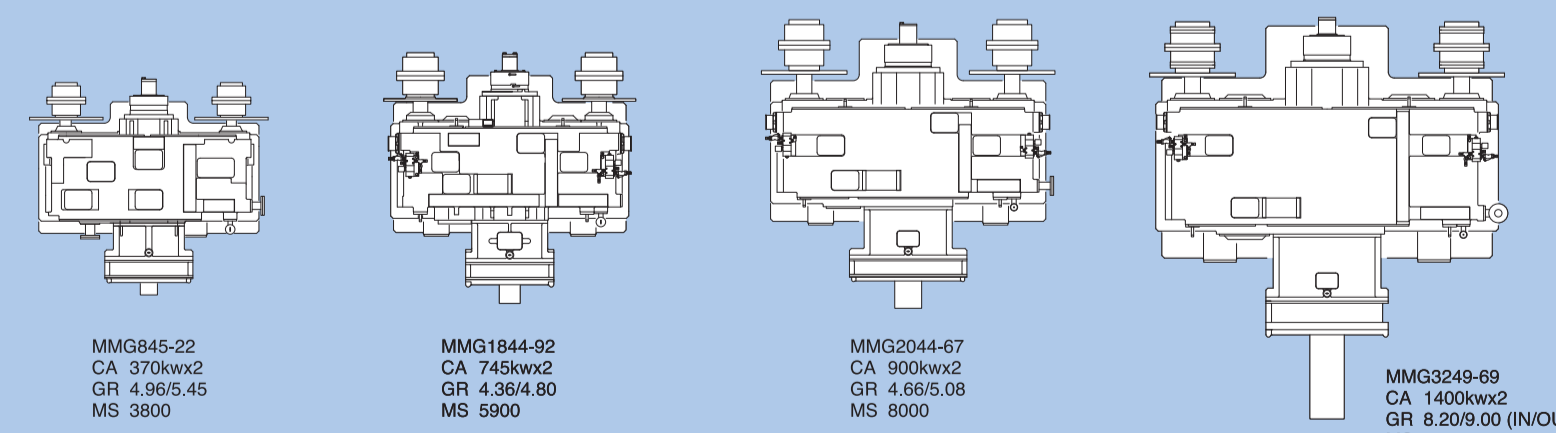

SPECIAL TYPE STEP-UP GEAR

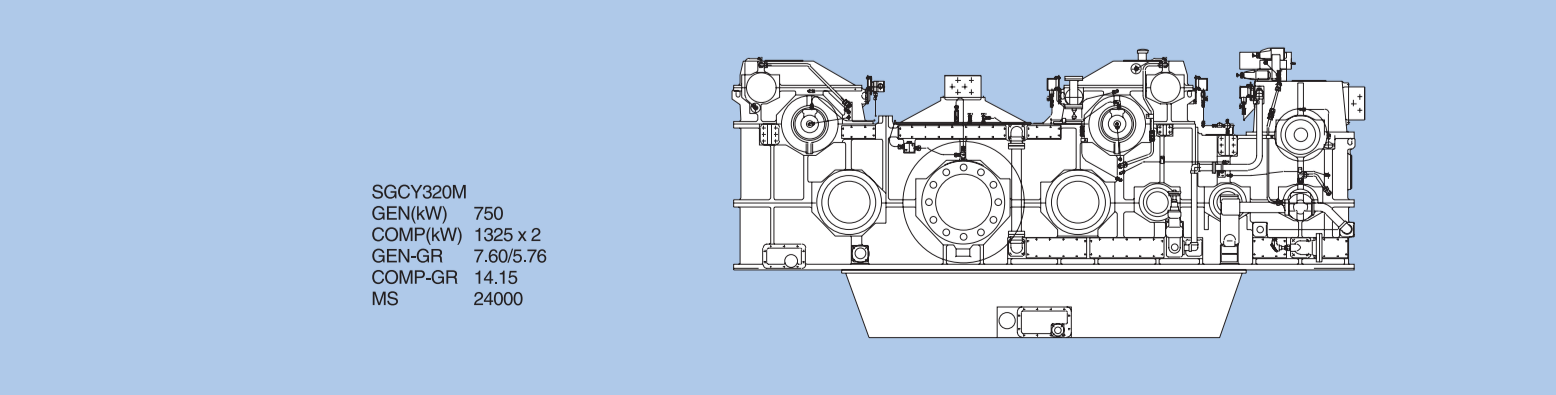

STEP-UP GEAR with OMEGA-CLUTCH DRIVEN by MAIN ENGINE FRONT END for GENERATOR DRIVE

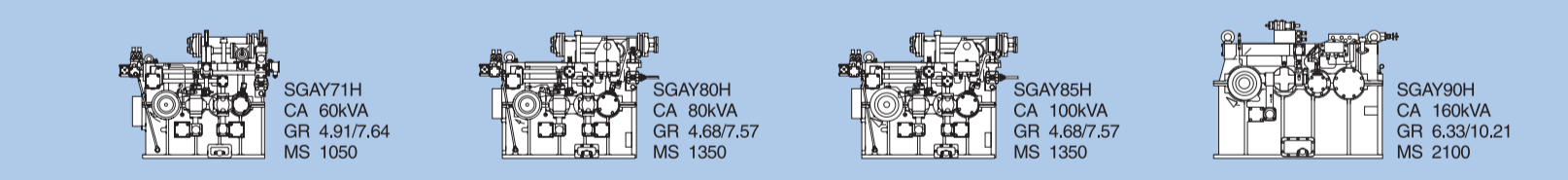

STEP-UP or REDUCTION GEAR with HYDRAULIC CLUTCH DRIVE by MAIN ENGINE FRONT END for OIL PUMP DRIVE

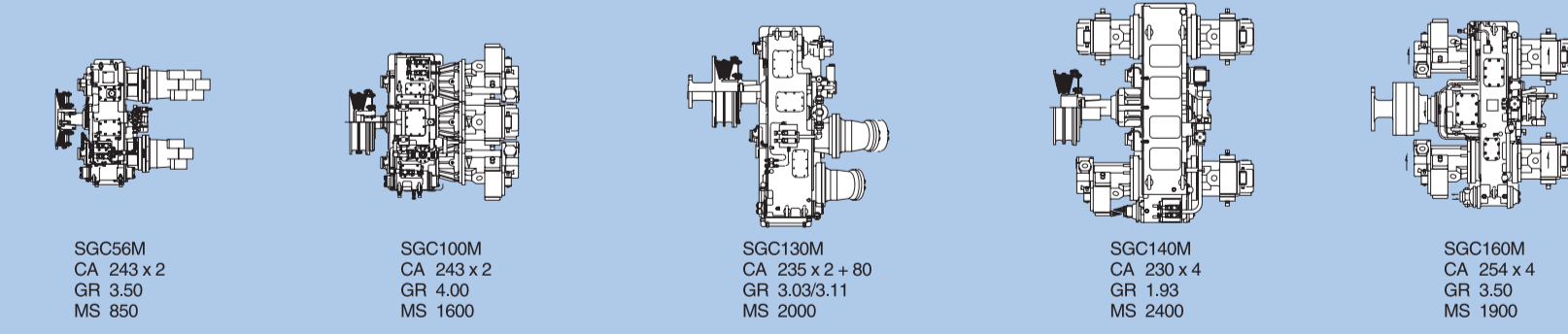

SPECIAL TYPE MARINE GEAR

